

Table of Contents

Introduction	3
Welcome	3
Boss 302 history	4
Breaking-in your vehicle	5
Boss® 302 Unique Features	6
Unique features	6
Performance gauges	9
Driving your Boss® 302	19
AdvanceTrac®	19
Driving through water	19
Ground clearance	19
Washing your vehicle	20
Chassis	21
Tire Information	22
Wheel lug nut torque	22
Roadside Emergencies	27
Wrecker towing	27
Maintenance and Specifications	30
Battery	31
Engine oil	31
Refill capacities	32
Engine drivebelt	35

Table of Contents

Track Use Preparation

37

Warranty Coverage

40

All rights reserved. Reproduction by any means, electronic or mechanical including photocopying, recording or by any information storage and retrieval system or translation in whole or part is not permitted without written authorization from Ford Motor Company. Ford may change the contents without notice and without incurring obligation.

Copyright © 2011 Ford Motor Company

2

Introduction

WELCOME

Congratulations on your decision to purchase the latest from Ford — the Boss® 302. If you've owned or leased a Ford product in the past, we're glad you're back. If this is your first Ford vehicle, welcome to the Ford family! We are confident that our dedication to performance, quality, craftsmanship and customer service will ensure many miles of exhilarating, safe and comfortable driving in your new Boss® 302.

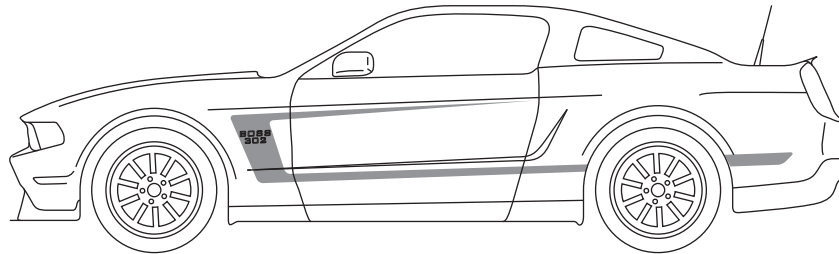

Your choice of a Ford product is an intelligent and informed one. Ford strives to build engaging vehicles that involve the driver in every aspect of the driving experience. Although performance is at the heart of every Ford vehicle, we go much further. Our goal is to deliver a comprehensive, complete vehicle, sweating the details such as the sound of the exhaust, the quality of the interior materials, and the functionality and the comfort of the seats, to ensure that the driver enjoys not only exceptional performance but an outstanding *driving environment* as well. In the Boss® 302, that philosophy is expressed by a sophisticated powertrain, outstanding chassis dynamics and significant interior and exterior enhancements.

This supplement complements your Mustang Owner's Guide and provides information specific to the Boss® 302. By referring to the pages listed in this supplement, you can identify those features, recommendations and specifications unique to your new vehicle. If there are any discrepancies between this supplement and the Mustang Owner's Guide, this supplement shall supersede the information found in the Mustang Owner's Guide.

Introduction

BOSS 302 HISTORY

The Ford Mustang isn't just a car – it's an American automotive icon. And of the more than 9 million Mustangs sold to date over the five different platform generations covering the past five decades, there is arguably one high-performance model that stands above the rest in both reverence and respect among enthusiasts, racers and collectors alike. That's the Boss® 302.

Many consider the 1969-70 model years to be the high-water mark of the so-called "Muscle Car era." Semon E. "Bunkie" Knudsen was hired as president in an effort to pump new blood into the Ford Motor Company product pipeline.

Bunkie set out to secure Ford corporate bragging rights once and for all with an all-new racing-inspired Mustang model. Knudsen wanted a Mustang race car to champion a hot, new Ford small-block V-8 that could power a competitive entry in the Trans Am road racing series. So he tagged designer Larry Shinoda with the task of designing what a production version of the new race car should look like.

Knudsen had ordered that his new road-racing Mustang not only be powerful, but also that it should be "absolutely the best-handling street car available on the American market." Shinoda came up with racy looks for the new Mustangs that he was designing for "the boss" – which was how he referred to Knudsen. Both the styling of "the Boss' car," and the name, stuck.

Enter the 1969 "Boss® 302" built to compete in the performance car arena. The Boss® 302 was built so that Ford could go out and win in Trans Am racing. Shinoda's design for the Boss® 302 included front and rear spoilers, racy side stripes, a matte-black hood and even rear window louvers – but it was performance that really helped sell the cars.

The Boss® 302 dazzled the enthusiast press, established a new level of interest in Ford performance, and became a force to be reckoned with on the racetrack. The Boss® 302 was edged out of winning the 1969 Trans Am racing series in the car's inaugural season. But Parnelli Jones and George Follmer piloted their Boss® 302 Mustangs to the victory circle more than any other team in the hotly contested 1970 campaign, giving Ford the manufacturer's championship, all while the road going versions were building "street cred."

Introduction

The Boss® 302's DNA of a unique 5.0-liter powertrain, superlative handling and a direct link to racing had built a legacy over the years that has come to epitomize what a high-performance Mustang is all about. To Ford's credit, no new Mustang would wear that name again until such time that the factory could put together all three race-inspired ingredients in a way that remains true to the Boss® 302's heritage.

That time is now.

Today, the Boss® 302 Mustang rides again for 2012 – both in name and the spirit of the original. Our thanks to Knudsen for the Boss Mustang legend, and to Shinoda for the looks and even the name itself. And now our thanks go to the men and women at Ford who have worked so hard to make sure that the new Boss® 302 is a legitimately worthy, race-bred successor of a Mustang performance legend!

-- John M. Clor

Author, *Mustang Dynasty*

BREAKING-IN YOUR VEHICLE

Your vehicle requires a break-in period. Drive your new vehicle at least 100 miles (160 km) before performing extended wide open throttle maneuvers and at least 1,000 miles (1,600 km) before performance/competition conditions. Vary your speed frequently in order to give the moving parts a chance to break in.

Boss® 302 Unique Features

UNIQUE FEATURES

Boss® 302

- Boss® 302 high performance V8 engine
- Forged pistons and rods
- Runners in the box intake manifold
- CNC machined high-flow ported aluminum cylinder heads
- Steel-backed high RPM clutch
- Unique steering tuning
- Unique chassis tuning with manually-adjustable dampers
- Brembo four-piston front brakes with unique high-performance rear brake pads
- Low expansion brake hoses
- Unique grille, front lower fascia and rear lower fascia
- Unique hood stripes and body side stripes
- Boss® 302 interior package with unique interior finish panels and instrument cluster (Recaro seats optional)
- Quad exhaust with rear and side exiting pipes
- Unique staggered width 19x9 inch and 19x9.5 inch wheels with summer only performance tires
- 3.73 rear axle ratio with limited slip (optional Torsen® differential)
- High performance radiator and engine oil cooler
- AdvanceTrac® stability enhancement system with sport mode specifically calibrated and race track tuned. Refer to the *Driving* section in your *Owner's Guide* for more information.
- **TRACKEY™** - After delivery, your Ford dealer can reprogram your engine control module to use the red key as a **TRACKEY™** . Once enabled, the **TRACKEY™** provides optimal racetrack performance via a unique engine calibration. See <http://www.trackey.ford.com> for more information.

Boss® 302 Unique Features

Boss® 302 with Laguna Seca Package

- Unique Laguna Seca chassis tuning with manually-adjustable dampers
- Unique steering tuning
- Performance gauge package
- Rear seat delete (creating a two-seat configuration) with added brace for improved body stiffness
- Boss® 302 interior package with standard Recaro seats
- Unique staggered width 19x9 inch and 19x10 inch wheels with R-compound summer only performance tires
- 3.73 rear axle ratio with standard Torsen® differential
- Unique red body/interior accents
- Additional Ford Racing parts
 - Front splitter (track use only - see Warranty information for more details) The front splitter included in the Laguna Seca Package is intended for race track use only and is not legal for on-street driving. It may degrade crash performance and void the vehicle warranty. The front splitter must be installed by the customer.
 - Front brake cooling kit
 - Transmission cooling scoop

Boss® 302 Unique Features

INSTRUMENT CLUSTER

Standard cluster

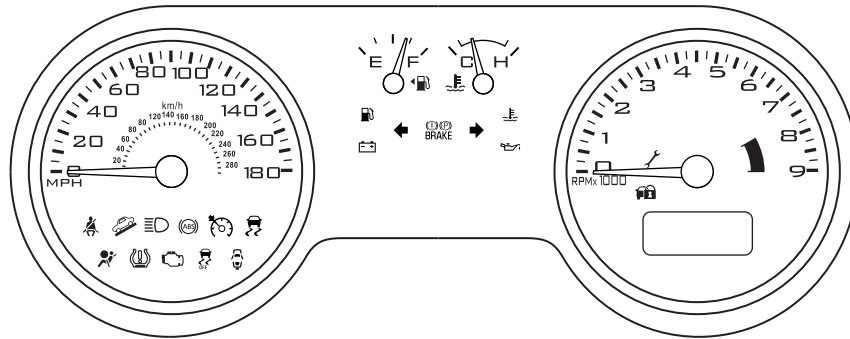

Metric cluster

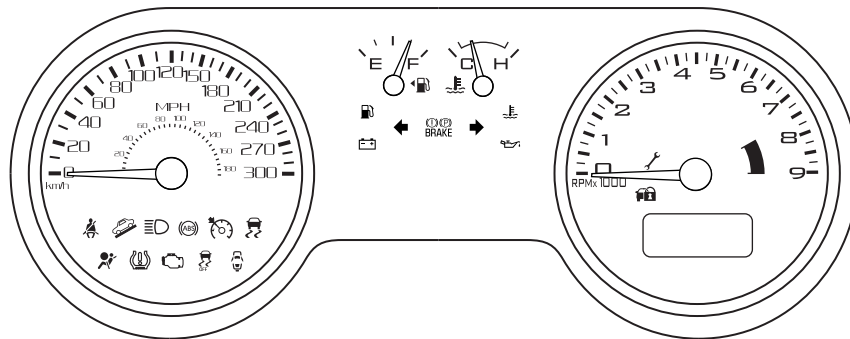

Boss® 302 Unique Features

PERFORMANCE GAUGES

Your vehicle may be equipped with a dash mounted gauge pack that contains oil pressure, engine coolant temperature, and performance gauges.

 **WARNING:** The performance gauge function should only be used while in a track environment. The driver's primary responsibility is the safe operation of their vehicle, only use this feature when it is safe to do so.

Oil pressure gauge - measures oil pressure from 0-100 psi (0-689 kPa)

Note: It is normal for the oil pressure to read high (80 -100 psi) (551 - 689 kPa) during a cold start and may exceed 100 psi (689 kPa) in some conditions. The oil pressure gauge needle may also move quickly back and forth (flutter) in some conditions.

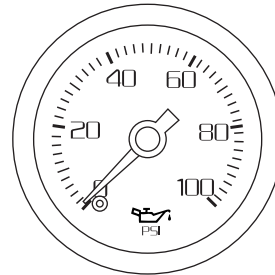

Engine coolant temperature gauge - measures engine coolant temperature 100-260°F (38-127°C).

Note: It is normal for the engine temperature needle to NOT point at 12 o'clock for stabilized driving.

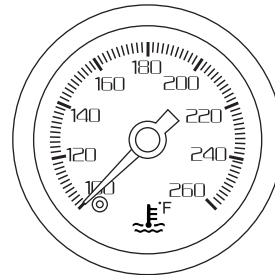

Boss® 302 Unique Features

Performance gauge - performs the following functions:

- Real time mode – measures G force/acceleration (**Note:** Requires initial calibration) See Setup information.
- 1/4 mile data including reaction time
- 0-60 mph times
- 60-0 mph distances
- Horsepower - **Note:** This reading will vary from advertised engine horsepower. It includes losses through the drivetrain and other factors such as fuel octane, wind, weight, road grade, etc.
- Setup

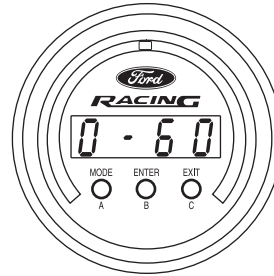

This gauge is intended for off-road use only (racetracks or other controlled courses or settings).

Real time mode:

The performance gauge calculates/displays acceleration and G-forces while in real time mode. The customer is required to calibrate/initialize the performance gauge to ensure proper acceleration measurements while in real time mode (see Setup section). At vehicle start up, the performance gauge defaults to real time mode. The gauge stays in real time mode until the user selects one of the other five operating modes. The gauge returns to real time mode after exiting the operating modes.

In real time mode, the gauge will display the driver's choice of acceleration/deceleration or lateral g-forces on an LED graph and display. Acceleration forces will be displayed on the bar graph to the right of center. Deceleration forces will be displayed on the bar graph to the left of center.

- Press B to change the display to the lateral axis.
- See bar graph forward/lateral high/low under Setup to change the range of g-forces capable of being displayed on the LED.

Peak Recall – While in any mode, the gauge will record the highest g-force values for all four axes (accel, decel, left and right).

- Press C to view these values.
- Press A to move to the next value.
- Press B to clear the value.

10

Boss® 302 Unique Features

The gauge will return to real time mode if no buttons are pressed for four seconds. Peak g-forces are displayed as shown below.

- PAC - Peak Acceleration g Forces
- PdC - Peak Deceleration g Forces
- PLG - Peak Lateral Left g Forces
- PrG - Peak Lateral Right g Forces

1/4 mile mode: To enter 1/4 mile mode, do the following:

1. Press MODE until "9tr" is displayed.
2. Make sure the vehicle is at a complete stop at the beginning of your course, then press ENTER to confirm.
3. The display will show "CAL" to indicate mode has been entered. Do not move your vehicle while the gauge displays "CAL" or you will get false readings.
4. Begin your 1/4 mile acceleration when the gauge lights the LED bar graph and the display reads "Go".

Note: If you have reaction time turned on in the Setup mode, the display will change from "CAL" to "trEE" and the LED bar graph will change from yellow to red. When the graph is fully lit, the display will change to "Go".

During 1/4 mile mode operation, the gauge will calculate 1/4 mile time (ET) and speed (mph), reaction time (if activated in the Setup mode), and peak G's. The 1/4 mile timer does not start until the vehicle starts accelerating unless you have reaction time enabled. If reaction time is enabled, the timer starts when "Go" is displayed. Accelerate through the entire 1/4 mile distance in order for the gauge to provide you with results.

During 1/4 mile acceleration, the gauge will display an increasing number which is your calculated speed in mph. When the 1/4 mile distance has been reached, the gauge will display "Lrun" (last run) followed by "rt" (reaction time) if enabled, "Et" (elapsed time), and "SPEd" (speed) at the end of the 1/4 mile.

The gauge will display results once and then display "Lrun" and flash a bar graph.

- To review your results again, press B. The gauge will display your reaction time, elapsed time, 1/4 mile speed, and peak G's.
- To save your results as your new best, press A to display SAVE, then press B to confirm.

Note: Saving a run as your new best run will overwrite your previous best run. The gauge will automatically save/overwrite your stored last run each time you make a new pass.

Boss® 302 Unique Features

- To view your best run, press A until “brun” is displayed, then press B to view.
- To view the difference between your last run and your best run, press A until “dIFF” is displayed, then press ENTER to view.
- To exit 1/4 mile mode, press A until “donE” is displayed, then press B to confirm, or press C to exit. If you need to exit 1/4 mile mode before accelerating, press the C button. The gauge will also timeout/exit 1/4 mile mode if “Go” is displayed for more than 60 seconds.
- You may view your previous 1/4 mile results at any time by entering 1/4 mile mode and then press C to view your results.
- The gauge returns to real time mode when exiting this 1/4 mile mode.

0-60 mph mode:

To select 0-60 mph mode, press the MODE button until “0-60” is displayed. Make sure the vehicle is at a complete stop at the beginning of your course, and then press ENTER to confirm. The display will show “CAL” to indicate mode has been entered. Do not move vehicle while “CAL” is displayed or you will obtain false readings.

During 0-60 mph mode, the gauge will determine your vehicle’s 0-60 mph acceleration time in seconds and also G-force. Once “Go” is displayed and LED bar lit, accelerate your vehicle to 60 mph. During acceleration, the gauge will display increasing mph. When 60 mph has been reached, the gauge will flash LED bar and display “Lrun”. At this time, bring your vehicle to a stop in a controlled fashion for the gauge to view your results.

To view your results, press the B button. To save your results as your new best, press A once to display “SAVE”, then press B to confirm. Saving a run as your new best run will overwrite your previous best run. The gauge will automatically save/overwrite your last run file each time you make a new pass. To view your best run, press A until “brun” is displayed and then press B to view. To view the difference between your last run and your best run, press A until “dIFF” is displayed and then press enter to view. To exit to Real time mode, press A until “donE” is displayed, then press B to confirm, or press EXIT.

You may view results at any time by entering 0-60 Mode and then pressing C to display results. When is “Go” displayed, 0-60 mode may be exited prior to beginning acceleration by pressing EXIT. 0-60 mode will time out and return to Real time mode if acceleration is not started one minute after “Go” is displayed.

Boss® 302 Unique Features

60-0 mph mode:

To select 60-0 mph mode, press the MODE button until “60-0” is displayed. Make sure the vehicle is at a complete stop at the beginning of your course, and then press ENTER to confirm. The display will show “CAL” to indicate mode has been entered. Do not move vehicle while “CAL” is displayed or you will obtain false readings. During 60-0 mph mode, the gauge will determine your vehicle’s 60-0 mph braking distance in feet. You will need to accelerate your vehicle from 0 to 60 mph and then safely bring your vehicle to a stop for the gauge to make these calculations.

Once “Go” is displayed and LED bar lit, accelerate your vehicle to 60 mph. During acceleration, the gauge will display increasing mph. When slightly more than 60 mph has been reached, the gauge will flash LED bar and display “StoP”. At this time, bring your vehicle to a stop in a controlled fashion for the gauge to calculate your braking distance. You must reach or exceed 60 mph; stopping the vehicle before “StoP” is displayed on the gauge will not allow results to be calculated and displayed.

Note: If the performance gauge does not correctly display your 60-0 stopping distance, cancel the run by pressing the C button and perform the vehicle calibration procedure (see the Vehicle Calibration section), then retry the 60-0 mph mode.

When 0 mph has been reached, the gauge will display “donE” followed by your results for 60-0 mph braking distance. The result is displayed in feet. To view your results again, press B. To save your results as your new best, press A once to display “SAVE”, then press B to confirm. Saving a run as your new best run will overwrite (erase) your previous best run. The gauge will automatically save/overwrite your last run file each time you make a new pass. To view your best run, repeatedly press A until “brun” is displayed and then press B to view. To view the difference between your last run and your best run, press A until “dIFF” is displayed and then press enter to view. To exit to Real time mode, press A until “donE” is displayed then press B to confirm, or just press the EXIT button.

You may view results at any time by entering 60-0 Mode and then pressing C to display results.

60-0 mode may be exited prior to beginning acceleration by pressing the EXIT button. 60-0 mode will time out and return to Real time mode if acceleration is not started one minute after “Go” is displayed.

Boss® 302 Unique Features

Horsepower mode - Note: This reading will vary from advertised engine horsepower. It includes losses through the drivetrain and other factors such as fuel octane, wind, weight, road grade, etc. In order to obtain the most accurate numbers, it is important that the correct vehicle weight be stored in the gauge (see Setup section). The gauge has been preset with the weight preset to 3830 lb (1737 kg) and should be modified as needed. To select horsepower mode, do the following:

1. Press MODE until “HP” (horsepower) is displayed.
2. Make sure the vehicle is at a complete stop at the beginning of your course, then press ENTER to confirm. The display will show “CAL” to indicate mode has been entered.

When the display reads “Go”,

1. Lightly accelerate your vehicle through first gear.
2. Shift between gears at approximately halfway to redline.
3. In second gear, (ideally at 2,000 rpm) accelerate under full throttle up to, but not exceeding, the engine redline.
4. Let off the accelerator and safely stop the vehicle to view your results once redline has been reached.
5. The gauge will display your horsepower results. Press B to view your results again. See the section on viewing best run/last run/etc results.

Setup mode: (There are eight parameters that can be adjusted in Setup mode).

To select Setup mode, do the following:

1. Press the mode button until “Sup” is displayed.
2. Press the enter button to confirm.
3. Press the exit (C button) to exit setup mode.

Vehicle calibration:

Performing this operation will be necessary in order to obtain correct readings from the performance gauge while operating in real time mode and performance modes. The vehicle calibration function allows the gauge to determine its angle, pitch, and general location in your vehicle, and to compensate accordingly, allowing you to mount it virtually anywhere in any position, and still get accurate readings.

To select vehicle calibration mode, enter Setup as described above, then press the A button until “VCAL” is displayed, then press ENTER to confirm. “REDY” should display. Bring the vehicle to a complete stop on a flat and level surface and then press ENTER. “HOLD” will display. At

14

Boss® 302 Unique Features

this point, the gauge is taking a stationary reading. Do not move the vehicle at this time or your calibration will be incorrect and you will need to re-calibrate. Next, the gauge will light all LEDs on the radial bar graph and display “GO”. Launch your vehicle in a manner using moderate, steady acceleration with a goal of reaching 15 mph in three to four seconds (with 3-1/2 seconds as your goal). Accelerate forward, shifting smoothly if necessary. When finished with the calibration procedure, the gauge will display “DONE” for three seconds and then return to Real Time mode. Accelerating too aggressively or too passively in the vehicle calibration mode will result in an incomplete or inaccurate calibration. It is very important while performing the acceleration part of the vehicle calibration that the vehicle not bounce up and down or move side to side. During this calibration process, DO NOT spin the tires, slide the vehicle sideways, powershift, lug, jerk, bounce or turn the vehicle. Doing so will cause an incorrect calibration, and you will need to repeat the calibration process. To check your calibration, change your display to Real Time Lateral mode (see Real Time mode). When you accelerate and brake in a straight line you should see very minimal if any lateral G force displayed. If you do, repeat the calibration process as outlined above. If problem persists, contact Auto Meter tech support for further assistance.

Roll out: This function only affects the 1/4 mile function. Roll out is the distance that your vehicle travels before the 1/4 mile timer (ET) starts. With a roll out of zero, the gauge will give you a slower ET reading than a drag strip timer, as the gauge will start the timer the instant the car moves. A zero roll out will be the most accurate indication of how long it takes your car to cover a standing 1/4 mile. Increasing your roll out distance will decrease the ET readings that the gauge will display as you are giving your vehicle a head start up to 18 inches before the timer starts.

To select roll out:

1. Enter Setup mode, then press A until “UL65” is displayed.
2. Press B to confirm. The number displayed represents roll out distance in inches, and may be adjusted from 0 to 18.
3. Press A to increase the value shown. Press C to decrease.
4. Press ENTER to confirm your setting when the desired roll out value is displayed.

Boss® 302 Unique Features

Vehicle weight: Accurate weight is necessary for the gauge to make a valid horsepower calculation. The vehicle weight has been preset to 3830 lb (1737 kg).

To enter/modify vehicle weight, do the following:

1. Repeatedly press the MODE button until “SUP” is displayed.
2. Press ENTER to confirm.
3. Press A until “ULBS” is displayed.
4. Press ENTER to confirm. The value displayed is total vehicle weight in pounds (lb). To increase the value, either press or press and hold the A button. To decrease, press or press and hold the C button. Weight is adjusted in ten pound increments and can be set to any value from 500 lb (227 kg) to 8,000 lb (3629 kg).
5. When the correct value is reached, press B to confirm.
6. To exit and return to real time display, press EXIT (C button). A lower than actual weight setting will result in a lower than expected horsepower reading. The opposite is true with a higher than actual weight setting.

Bar graph forward high setting:

The bar graph forward high mode allows you to adjust the G force scale for forward acceleration as shown on the gauge when operating on the forward axis in real time mode. For example, if you set the “bGFH” to 1g, when the bar is fully lit on the right hand (acceleration) side, the vehicle is achieving 1g of acceleration force or more.

To select bar graph forward high mode, enter Setup, then press the A button until “bGFH” is displayed. Press ENTER to confirm. The current setting should be displayed, and can be adjusted up and down from .3 to 2.0 G's using the A and C buttons. When the desired result is displayed, press ENTER to confirm. The bar graph high setting is preset to 0.7G.

Bar graph forward low setting:

The bar graph forward low mode allows you to adjust the G force scale for rearward acceleration (deceleration or braking) as shown on the gauge when operating on the forward axis in real time mode. For example, if you set the “bGFL” to 1g, when the bar is fully lit on the left hand (deceleration) side, the vehicle is achieving 1g of force or more during braking.

Boss® 302 Unique Features

To select bar graph forward low mode, enter Setup, then press the A button until “bGFL” is displayed. Press ENTER to confirm. The current setting should be displayed, and can be adjusted up and down from .3 to 2.0 G’s using the A and C buttons. When the desired result is displayed, press ENTER to confirm. The bar graph low setting is preset to -0.7G.

Bar graph lateral setting:

The bar graph lateral mode allows you to adjust the G force scale for lateral acceleration (cornering) as shown on the gauge when operating on the lateral axis in real time mode. For example, if you set the “bGL” to 1g, when the bar is fully lit on either side, the vehicle is achieving 1g of force or more during cornering.

To select bar graph lateral mode, enter Setup, then press A until “bGL” is displayed. Press ENTER to confirm. The current setting should be displayed, and can be adjusted up and down from .3 to 2.0 G’s using the A and C buttons. When the desired result is displayed, press ENTER to confirm.

Reaction time:

Enabling this function allows the gauge to test your reaction time while in the 1/4 mile mode only. With reaction time on, the gauge will perform a dragstrip “Christmas Tree” start and then measure the time it takes between when it displays “Go” and when the vehicle starts to move.

- To enable or disable reaction time, enter Setup mode, and press A until “rEAC” is displayed. Press ENTER to confirm. The display will then read “on” if reaction time feature is enabled, or “off” if it is disabled.
- To enable reaction time, press A. To disable, press C. When the desired result is displayed, press ENTER to confirm.

Start G’s:

The Starting G’s setting allows the customer to adjust the sensitivity of the accelerometer within the performance gauge. This setting affects how quickly the gauge detects movement of the vehicle when determining vehicle start time. Too low of a setting may result in false starts due to engine vibration. Too high of a setting may result in the gauge not properly detected at the start of the run. The gauge has been optimally programmed to 0.7 G’s for this vehicle.

Boss® 302 Unique Features

Display on/off:

This allows the customer to turn on/off the performance gauge LED bar graph and seven segment displays. To enable Display on/off, simultaneously hold down buttons A and C to turn off the display. The gauge will display "DOFF" before turning off the display. To exit Display on/off, press any of the three front panel buttons. The gauge will then momentarily display "DON" and then enter the Real time operating mode. The LED bar graph and seven segment display will be turned off. The Ford oval will be illuminated during display off.

Driving your Boss® 302

ADVANCETRAC® STABILITY ENHANCEMENT SYSTEM

AdvanceTrac® sport mode

The AdvanceTrac® system provides an available sport mode specially calibrated for the Boss® 302 and its unique performance characteristics. This can be selected utilizing the stability control off switch. While in AdvanceTrac® sport mode, the selected steering option will be overridden and placed in sport mode. See the *Driving* section of the *Owner's Guide* for more information.

DRIVING YOUR VEHICLE THROUGH WATER

The Boss® 302 has aerodynamic devices attached to the underbody designed to help control airflow for superior performance. Therefore, the driver must be especially careful to avoid driving through deep or standing water. If driving through deep or standing water is unavoidable, proceed very slowly. Never drive through water that is higher than the bottom of the wheel rims. Water may enter through the air intake due to the vacuum generated in the engine. Damage caused by the intake of water in the engine is not covered by the warranty. Refer to *Tire information* for more information.

GROUND CLEARANCE

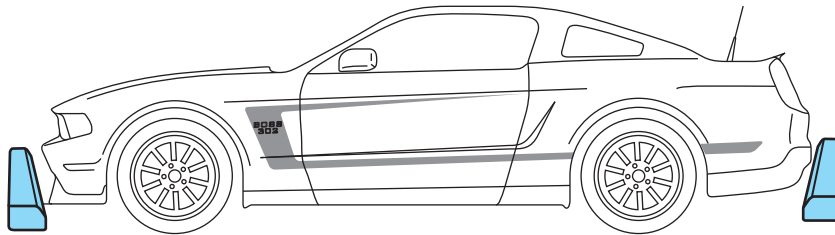

Because of low vehicle ground clearance, use caution when approaching curbs/curb stops from the front and rear as vehicle damage will occur. Additionally, when crossing speed bumps or driveway curbs, Ford recommends approaching at a very low speed.

Driving your Boss® 302

WASHING YOUR VEHICLE

Do not drive your vehicle through an automated, commercial car wash due to the vehicle's low ground clearance, tire width and track width. Wash your vehicle by hand, or by using a touchless commercial wash with no mechanical tracks on the floor. Do not use a commercial or high pressure wand on the striped surfaces or stripe edges.

TRAILER TOWING



WARNING: Never tow a trailer with this vehicle. Your vehicle is not equipped to tow. No towing packages are available through an authorized dealer.

Chassis

SUSPENSION

- MacPherson strut with L-arm front suspension
- 8.8 inch solid rear axle with limited slip differential (3.73:1 ratio)

Boss® 302:

- 34.6 x 4.4 mm tubular front stabilizer bar
- 25.0 mm solid rear stabilizer bar
- Tokico twin tube adjustable shocks and struts
- 26.0 N/mm front and 32.4 N/mm rear coil springs

Boss® 302 with Laguna Seca package:

- 34.6 x 4.4 mm tubular front stabilizer bar
- 26.0 mm solid rear stabilizer bar
- Tokico twin tube adjustable shocks and struts
- 24.0 N/mm front and 33.5 N/mm rear coil springs

ADJUSTABLE SUSPENSION DAMPERS

Your vehicle has adjustable suspension dampers. The adjustment controls are located on top of the damping rods and can be adjusted with a small screwdriver. Remove the cap to access the control for the front strut.

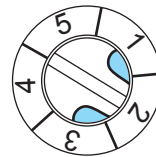

To access the rear shock, pull the carpet back in the trunk area. Then, lift the trim panel and pull rearward to expose the adjustable suspension damper.

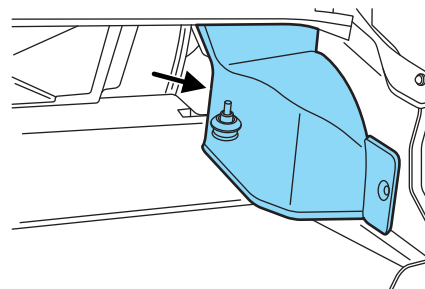

Position (1) has the lowest damping force which provides for a more comfortable ride. Position (5) has the highest damping force which provides more responsive handling. Position (2) is the factory setting (shown in graphic).

Left and right dampers should always be set to the same dial position. Front and rear can be adjusted independently to change vehicle response.

Tire Information

WHEELS

Your Boss® 302 is equipped with unique wheels matched to the tires. These wheels are more susceptible to damage due to their diameter, width and low profile tires. To avoid damage to your wheels:

- Maintain proper tire pressure (see *Tires* in this supplement).
- Do not drive your vehicle through an automated, commercial car wash due to the vehicle's low ground clearance, tire width and track width. Wash your vehicle by hand, or by using a touchless commercial wash with no mechanical tracks on the floor.
- When installing wheels, always torque lug nuts to specification with a torque wrench.
- Inspect your wheels for damage on a regular basis. If a wheel is damaged, replace it immediately.
- In the event that you encounter an abnormally harsh impact, inspect the outer edge of your wheels, both inside and out, for damage.

Operating at high speeds

Your Boss® 302 is capable of high speeds and is equipped with tires rated for the vehicle's maximum speed, electronically limited to 155 mph (250 km/h). Remember to drive safely, obey all traffic laws and only operate your vehicle at high speeds at locations equipped and designed to do so safely. Before operating your vehicle at high speeds:

- Ensure correct tire pressures (see *Tires* in this supplement).
- Inspect wheels and tires for wear and damage. Replace any damaged wheels or tires.
- Do not operate your vehicle at high speeds with more than two passengers or while carrying cargo.

Wheel lug nut torque specifications

Retighten the lug nuts to the specified torque at 500 miles (800 km) after any wheel disturbance (tire rotation, changing a flat tire, wheel removal, etc.).

Bolt size	Wheel lug nut torque*	
	ft-lb	N•m
1/2 x 20	100	135

* Torque specifications are for nut and bolt threads free of dirt and rust. Use only Ford recommended replacement fasteners.

Tire Information



WARNING: When a wheel is installed, always remove any corrosion, dirt or foreign materials present on the mounting surfaces of the wheel or the surface of the wheel hub, brake drum or brake disc that contacts the wheel. Ensure that any fasteners that attach the rotor to the hub are secured so they do not interfere with the mounting surfaces of the wheel. Installing wheels without correct metal-to-metal contact at the wheel mounting surfaces can cause the wheel nuts to loosen and the wheel to come off while the vehicle is in motion, resulting in loss of control.

IMPORTANT TIRE INFORMATION

Your vehicle is equipped with unique wheels and tires designed to enhance performance. To continue providing this performance, extra care must be taken when operating and maintaining your vehicle.

Wheels and tires

Boss® 302	19 in. x 9.0 in. front, 19 in. x 9.5 in. rear cast aluminum wheels 255/40ZR19 front, 285/35ZR19 rear tires
Boss® 302 with Laguna Seca Package	19 in. x 9.0 in. front, 19 in. x 10.0 in. rear lightweight cast aluminum wheels 255/40ZR19 front, 285/35ZR19 rear tires (ultra high performance)

Tires

Your Boss® 302 is equipped with low profile, high performance tires that are designed to optimize the car's driving dynamics. These tires are not optimized for off-road or winter (snow or cold weather) performance, and their ride, noise and wear characteristics are different than non-performance tires. Also, because of their lower profile, the tires are more susceptible to damage due to potholes and rough roads. To ensure that your tires perform as intended, it is important that you maintain your tires properly.

- The Boss® 302 and Boss® 302 with Laguna Seca Package original equipment tires are optimized for maximum steering and handling performance. Ford does not recommend using these tires in cold temperatures of approximately 40°F (5°C) and below (depending on tire, surface and weather conditions). See your Ford dealer for recommended tires in these conditions.

Tire Information

- The Boss® 302 with Laguna Seca Package is equipped with ultra high-performance, dry weather-only summer tires that provide superior steering and handling.



WARNING: If equipped with the Laguna Seca Package, never drive with these tires in any wet conditions (rain, snow, ice, etc.) because they cannot channel water away and will slide risking serious injury.

- **Do not use tire chains** on the original wheels and tires of your vehicle. The use of any type of tire chain on these tires may damage your vehicle.
- Always maintain your tire pressures according to the tire information placard on the driver's door jamb, using an accurate gauge.
- Tire pressures are specified "cold" and should be checked after the vehicle has been parked for at least 3 hours. Do not reduce pressure of warm tires.
- Check your tire pressure often to maintain it properly. Tire pressure can diminish over time and fluctuate with temperature.
- Do not overload your vehicle. Maximum vehicle and axle weights are listed on the tire information placard.
- Extra caution should be taken when operating the vehicle near its maximum load, including assuring proper tire pressure and reducing speeds.
- Extra caution should be taken when operating on rough roads to avoid impacts that could cause tire damage.
- In the event that you encounter an abnormally harsh impact, inspect your tires for damage.
- Inspect your tires for damage on a regular basis. If a tire is damaged, replace it immediately.
- Proper suspension alignment is critical for maximum performance and optimal tire wear. If you notice uneven tire wear, have your alignment checked.

Tire Information

- When replacing tires, the only way to ensure original performance is to use the original equipment tire. If a different tire is used, it should be the same size, speed rating and load rating and be replaced as a set of four. Never mix tire brands.



WARNING: Snow tires must be the same size, load index, speed rating as those originally provided by Ford. Use of any tire or wheel not recommended by Ford can affect the safety and performance of your vehicle, which could result in an increased risk of loss of vehicle control, vehicle rollover, personal injury and death. Additionally, the use of non-recommended tires and wheels could cause steering, suspension, axle or transfer case/power transfer unit failure.

Winter driving

The original equipment tires on your Boss® 302 are designed for high performance steering and handling. They are not designed for winter use on ice or snow and cannot be used with snow chains. If you will be operating your vehicle in these conditions, winter or all-season tires must be used.

Do not operate your vehicle above posted speed limits and never perform high speed driving with winter tires, even in clear, dry driving conditions.

Tire rotation

Because your vehicle is equipped with unique larger tires on the rear wheels, you can only rotate the tires side to side. You must not rotate tires in a crisscross pattern or front to rear. If you notice that the tires wear unevenly, have them checked.

The tires on your Boss® 302 should be rotated every 5,000 miles (8,000 km). This will help your tires wear more evenly, providing better tire performance and longer tire life.

Tire Information

The optional Laguna Seca Package tires (255/40ZR19 front, 285/35ZR19 rear) are directional. Tire rotation is not recommended for directional tires.

- Boss® 302 (non-Laguna Seca) tire rotation (front tires at the top of the diagram)

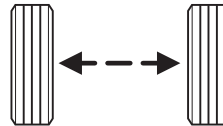
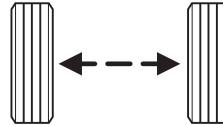

- Sometimes irregular tire wear can be corrected by rotating the tires.
- If your tires show uneven wear, ask an authorized dealer to check for and correct any wheel misalignment, tire imbalance or mechanical problem involved before tire rotation.
- After having your tires rotated, inflation pressure must be checked and adjusted to the vehicle requirements.

Roadside Emergencies

WRECKER TOWING

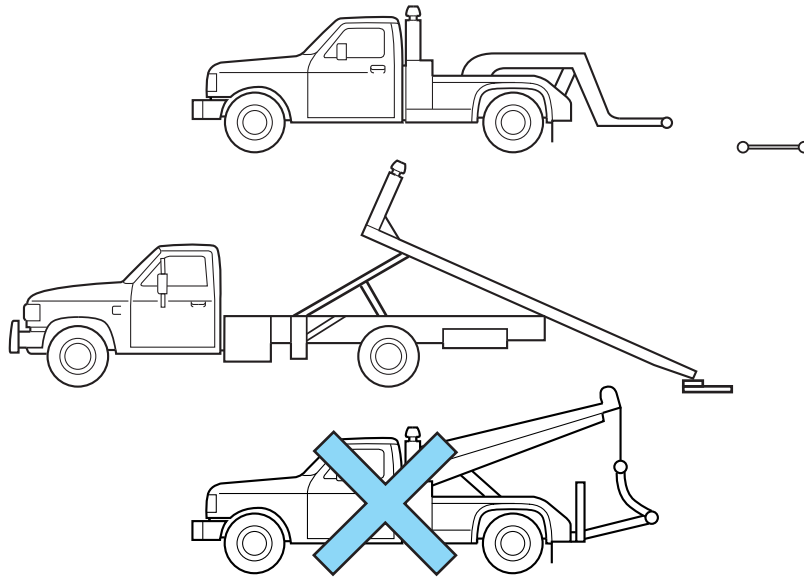

If you need to have your vehicle towed, contact your roadside assistance center or a professional towing service.

It is recommended that your vehicle be towed with a wheel lift and dollies or with flatbed equipment. When towing with a flatbed, 4x4 blocks must be used when loading/unloading your vehicle. Do not tow with a slingbelt. Ford Motor Company has not approved a slingbelt towing procedure.

If the vehicle is towed by other means or incorrectly, vehicle damage may occur.

Roadside Emergencies

Wheel lift

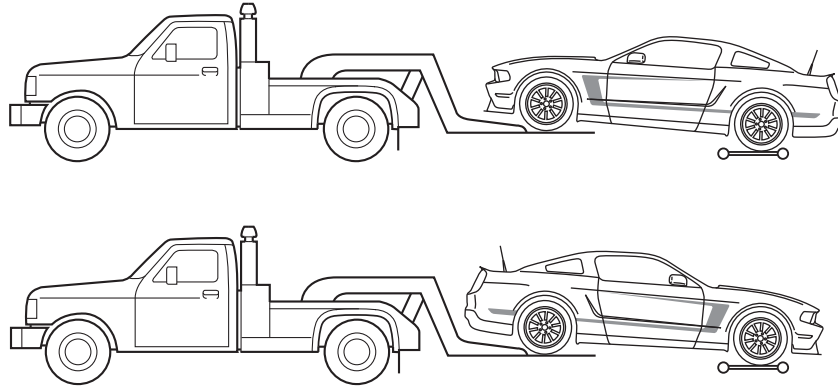

When towing the vehicle for front loading, the front tires must be 16 in. (41 cm) higher than the rear.

When towing the vehicle for rear loading, the rear tires must be 14 in. (35 cm) higher than the front.

Roadside Emergencies

Flatbed

The following diagram illustrates the maximum ramp angle allowable to load your vehicle on a flatbed. Vehicle damage may occur with greater angles.

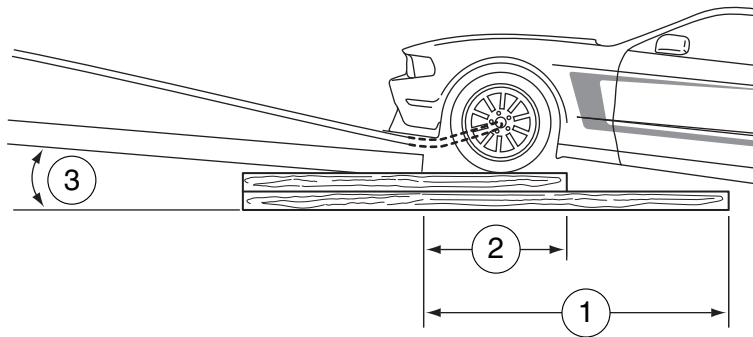

1. 36 in. (91 cm) 4x4 loading block
2. 18 in. (45.72 cm) 4x4 loading block
3. 11.5° maximum

Securing the rear of the vehicle

For flatbed towing, secure the rear of the vehicle by using axle straps or lasso straps around the rear axle. One strap is required on each side of the differential. **Note:** Using the standard T-slot attachment can damage the side exiting exhaust.

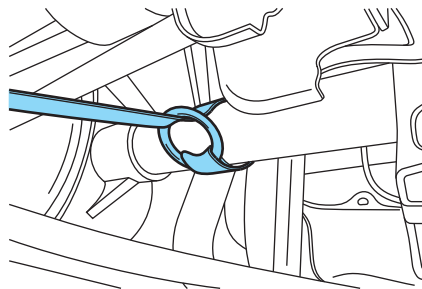

Maintenance and Specifications

BOSS® 302 V8 ENGINE

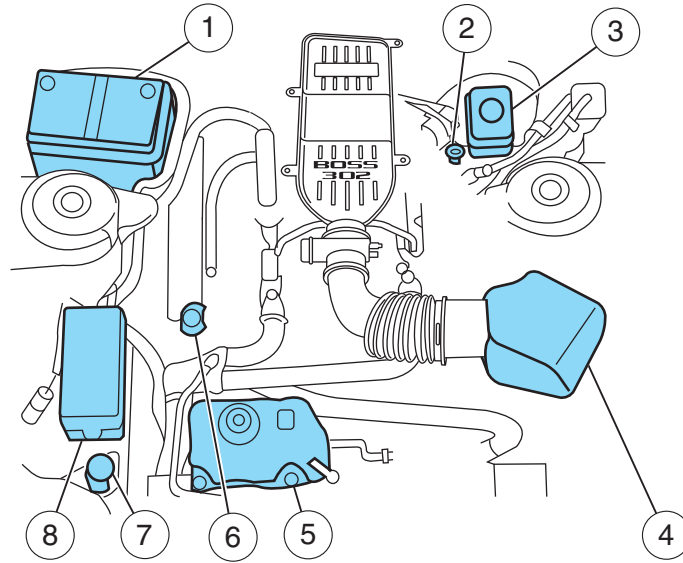

1. Battery
2. Engine oil dipstick
3. Brake fluid reservoir
4. Air filter assembly
5. Engine coolant reservoir
6. Engine oil filler cap
7. Windshield washer reservoir filler cap
8. Power distribution box

Maintenance and Specifications

MOTORCRAFT PART NUMBERS

Component	Boss 302 engine
Engine drivebelt	JK6-678
Lightweight battery	BXT-96R-500

ENGINE OIL RECOMMENDATION

Use Motorcraft® SAE 5W-50 full synthetic or an equivalent SAE 5W-50 full synthetic oil meeting Ford specification WSS-M2C931-B.

Do not use supplemental engine oil additives, cleaners or other engine treatments. They are unnecessary and could lead to engine damage that is not covered by Ford warranty.

Change your engine oil and filter according to the appropriate schedule listed in the *scheduled maintenance information*.

Maintenance and Specifications

MAINTENANCE PRODUCT SPECIFICATIONS AND CAPACITIES

Item	Capacity	Ford part name or equivalent	Ford part number / Ford Specification
Brake fluid	Between MIN and MAX lines on reservoir	Motorcraft® High Performance DOT 3 Motor Vehicle Brake Fluid	PM-1-C / WSS-M6C62-A or WSS-M6C65-A1
Engine oil (includes filter change)	8.5 quarts (8.0L)	Motorcraft® 5W-50 Full Synthetic Motor Oil	XO-5W50-QGT / WSS-M2C931-B
Engine coolant ¹	15.2 quarts (14.4L)	Motorcraft® Specialty Orange Engine Coolant with bittering agent (US) / Motorcraft® Specialty Orange Engine Coolant (Canada)	VC-3-B (US) CVC-3-B (Canada) / WSS-M97B44-D
Rear axle lubricant ²	5.0 pints (2.4L)	Motorcraft® SAE 75W-140 High Performance Synthetic Rear Axle Lubricant	XY-75W140-QL / WSL-M2C192-A
Rear axle fluid friction modifier	5 oz (148ml)	Additive Friction Modifier	XL-3 EST-M2C118-A
Fuel tank	16.0 gallons (60.5L)	—	—

Maintenance and Specifications

Item	Capacity	Ford part name or equivalent	Ford part number / Ford Specification
Manual transmission fluid ³	2.75 quarts (2.6L) ³	Motorcraft® Full Synthetic Manual Transmission Fluid	XT-M5-QS / WSD-M2C200-C
Windshield washer fluid	Fill as required	Motorcraft® Premium Windshield Washer Concentrate (US) / Premium Quality Windshield Washer Fluid (Canada)	ZC-32-A (US) CXC-37-(A, B, D, and F) (Canada) / WSB-M8B16-A2 / - -

¹Add the coolant type originally equipped in your vehicle.

²Rear axle lubricants do not need to be checked or changed unless a leak is suspected, service is required, the axle assembly has been submerged in water, or when subjecting your car to high-speed and/or competition use. The axle lubricant and friction modifier should be changed any time the rear axle has been submerged in water. The axle lubricant and friction modifier should also be changed after the initial (first) hour of high-speed operation or if the vehicle is subjected to track or competition conditions; thereafter changing the axle lubricant and friction modifier every 12 hours (under these conditions).

Fill 1/4 - 9/16 inch (6-14 mm) below bottom of fill hole.

³Fill to within 1/8 inch (3 mm) of bottom of fill hole.

Maintenance and Specifications

USING THE RIGHT BULBS

Function	Trade number
Headlamp	H13

DRIVETRAIN

Item	Description	
Rear axle	8.8 in. solid rear axle with limited-slip differential 3.73:1 ratio	
Driveshaft	2-piece steel	
Transmission	MT82 6-speed manual with integral clutch housing	
Gear ratios	<i>Gear</i>	<i>Ratio</i>
	1st	3.66
	2nd	2.43
	3rd	1.69
	4th	1.31
	5th	1.00
	6th	0.65
	Reverse	3.32

ENGINE INFORMATION

Item	Description
Configuration	90-degree V8 Aluminum block Aluminum high flow cylinder heads Engine weight - 444 lb. (201 kg)
Bore x stroke	92.2 x 92.7 mm (3.63 x 3.65 inches)
Displacement	302 cubic inches (5.0L)
Compression ratio	11.0:1

Maintenance and Specifications

Item	Description
Valve train	Compact RFF (roller finger followers) Four valves per cylinder
Cam timing	Twin independent variable
Fuel system	Sequential mechanical returnless fuel injection
Ignition system	Coil on plug, two knock sensors
Firing order	1-5-4-8-6-3-7-2
Throttle body	Single bore 80 mm
Pistons	Forged aluminum
Crankshaft	Fully counterweighted forged steel
Connecting rods	High strength forged powder metal/floating pin
Intake manifold	Runners in a box composite
Exhaust manifolds	Pulse separated stainless steel tubular headers

Engine drivebelt routing

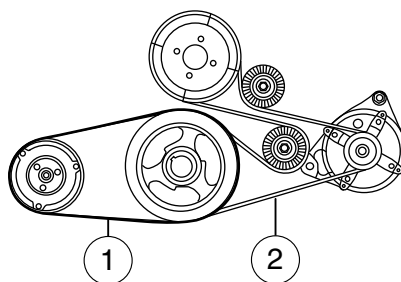

1. Short drivebelt is on first pulley groove closest to engine.
2. Long drivebelt is on second pulley groove farthest from engine.

Maintenance and Specifications

REAR SEAT DELETE PANELS (IF EQUIPPED)

In the event of battery failure, you can access the trunk area by doing the following:

1. Remove the two top fasteners by turning them counterclockwise.
2. Remove the trunk access panel (located behind the cross brace) by pulling it slightly down while pushing it rearward (toward the trunk).

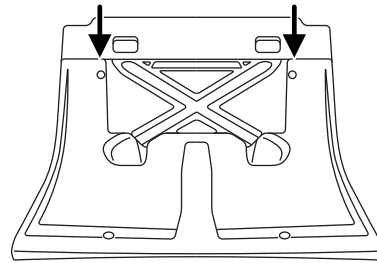

To remove the rear floor panel, do the following:

1. Remove the two top fasteners by turning them counterclockwise.
2. Lift the top of the two bottom fasteners with a flat-end screwdriver, then remove them.
3. Remove the rear floor panel.
4. Remove the trunk access panel (located behind the cross brace) by pulling it slightly down while pushing it rearward (toward the trunk).

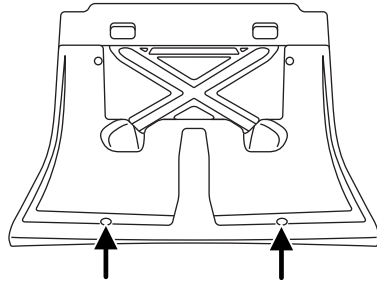

Track Use Preparation

TRACK PREPARATION

The Boss® 302 and Boss® 302 Laguna Seca edition have been rigorously proven out on race tracks. Below are recommendations for optimizing your Boss® 302 for a track day event.

- For optimal performance, premium fuel is recommended.
- Change brake fluid to Super DOT 4 to improve track performance of braking system (WSS-M6C65-A2), Ford part number (YS4Z-19542-AA).
- Install Ford Racing front brake cooling kit (M-2004-MB) to improve brake cooling (standard on Laguna Seca edition).
- Remove rear brake dust shields to improve brake cooling.
- Install Ford Racing transmission cooling scoop (M-5025-MBR) to improve transmission cooling (standard on Laguna Seca edition).
- During extended track sessions in extreme temperatures or conditions, your Boss 302 may require additional engine cooling actions. If the water temperature warning light illuminates, return to the paddock and let the vehicle return to normal operating temperature while idling before turning the engine off. Prior to the next session, remove your Boss 302's upper grille from the front fascia. This will allow more cooling air to the radiator and allow the car to run extended sessions in extreme heat. Visit fordracing.com for additional parts to further enhance the powertrain cooling on your Boss 302.
- For extended track use, Ford recommends installing a rear differential cooler to improve rear axle cooling.
- Remove vertical rear tire spoilers at rear edge of rocker moldings.
- The Ford Racing front splitter kit (M-16601-MB, standard on Laguna Seca edition) can be installed to improve high-speed vehicle stability and handling. If the Ford Racing front splitter kit will be installed on a Boss 302 without the Laguna Seca package, Ford recommends installing the Laguna Seca edition rear spoiler in place of the standard rear spoiler to maintain aerodynamic balance. This front splitter is intended for race track use only and is not legal for on-street driving. It may degrade crash performance and void the vehicle warranty. The front splitter must be installed by the customer.

Track Use Preparation

- For track sessions, it is recommended to run 41 psi (283 kPa) hot for the OEM tires, front and rear.
 - Depending on track temperature, ambient temperature and driving style, you may need to reduce the starting tire pressure by as much as 4 psi (27 kPa).
 - The starting pressure may be lower in the rear tires relative to the front tires to achieve 41 psi (283 kPa) hot.
 - Reset tire pressures to placard recommended pressures before leaving the track.
- For improved track performance, Ford recommends **TRACKKEY™**, available through Ford Racing. See your local Ford dealer or go to <http://www.trackkey.ford.com> for more information (M-14204-MBTKA).
- Your Boss® 302 is equipped from the factory with Brembo 4-piston front calipers and unique, high-performance rear brake pads that will provide excellent performance under normal driving conditions. Ford recommends the following bedding procedure for race track driving be followed.

Note: Restore the vehicle to factory specifications prior to driving on public roads.

Brake burnishing procedure for race track driving

If the vehicle has to be driven on a track (racing) or in severe driving conditions, the following steps must be performed on a closed course, not on public roads:

- Burnish: 30 burnish stops at 60-0 mph (96-0 km/h), 0.4g deceleration, one mile (1.6 km) between stops. If the vehicle has more than 200 miles (322 km) on the brakes, skip this step and proceed to the Fade stops.
- Fade: 20 fade stops, at 65-0 mph (105-0 km/h), 0.85g deceleration or just below ABS activity, no dwell between stops
- Cool down: Minimum of five mile (8 km) cool down route, if on public roads (no brakes) run at 60 mph (96 km/h)
- Recovery: 30 recovery stops at 60-0 mph (96-0 km/h), 0.4 g deceleration, one mile (1.6 km) between stops
- Cool down: Minimum of five mile (8 km) cool down route, if on public roads (no brakes) run at 60 mph (96 km/h)

Track Use Preparation

Damper adjustment recommendations:

- Boss® 302 - Set all four dampers to position (5) for all tracks.
- Boss® 302 Laguna Seca edition - Set front dampers to position (5) and set the rear dampers to position (3), (4) or (5) depending on how smooth the track is or how much curbing the driver likes to use.
 - On a rough track, set the rear dampers to position (3).
 - On a smooth track with aggressive apex curbs, set the rear dampers to position (4), but only if the driver uses those curbs.
 - On a smooth track with mild FIA-type apex curbs, set the rear dampers to position (5).
- If the turn-in portions of the track are rough, reduce the front damper setting by one position until the Boss® 302 turns in on those rough portions.
- If the rear of the car is skipping over bumps during corner exit so that the driver has to reduce throttle input, reduce the rear damper setting by one position until the driver can apply appropriate throttle.

Warranty Coverage

WARRANTY COVERAGE

The Boss® 302 carries the same warranty as other Ford Mustang models. This information is covered in its entirety in the Ford Motor Company Warranty Guide.

The three unique Laguna Seca Package high performance parts (front splitter, front brake cooling kit, and transmission cooling scoop) are intended for track use and have no warranty coverage.

Warranty service for the Boss® 302 can be obtained at any Ford dealer nationwide.

Ford does not recommend modifying or racing Ford vehicles, as they are designed and built to be driven as delivered from the factory. The Ford Motor Company Warranty Guide discusses vehicle usage and the installation of aftermarket parts and their effect on warranty coverage.

Please see the Warranty Guide for complete information.

In the event the vehicle is intended for track use, and the loss of warranty coverage is not of concern, the following vehicle durability modification is required:

- **Ford recommends that you change your axle lubricant and friction modifier after the initial (first) hour of high-speed operation or if the vehicle is subjected to track or competition conditions; thereafter changing the axle lubricant and friction modifier every 12 hours (under these conditions).**
- **Ford recommends you change your oil and filter after your vehicle is subjected to track and/or competition conditions.**

Additionally, perform multi-point inspection and the maintenance outlined in the 150,000 mile (240,000 km) normal maintenance schedule of the *scheduled maintenance information* after track use. Refer to the vehicle service manual for removal and installation procedures. Replace with Genuine Ford and Motorcraft® service parts as needed.

These modifications may not necessarily protect your engine from damage in competition conditions. Subjecting your vehicle to competition conditions even with these proposed modifications may render repairs non-reimbursable under the warranty.